

New Fire Safety Requirements – Buildings Other than Dwellinghouses

On 6th April 2007, new fire safety requirements come into force. This guidance note sets out to highlight the main changes that will affect buildings other than dwellinghouses, including flats, shops, offices etc.

Approved Document B will be replaced by two new documents. **Approved Document B Volume 1** deals with ‘Dwellinghouses’; **Approved Document B Volume 2** deals with ‘Buildings Other Than Dwellinghouses’. The new documents can be downloaded from the Planning Portal web site - www.planningportal.gov.uk. (Located under professional user – building regulations.)

GENERAL

Fire Safety Information

A new Regulation (16B) has been introduced to ensure that sufficient information is recorded to assist the eventual owner/occupier/employer to meet their statutory duties under the Regulatory Reform (Fire Safety) Order 2005.

REMEMBER – PART B IS FOR LIFE SAFETY NOT PROPERTY PROTECTION

Management of Premises

New guidance is given on the need to ensure that management regimes are realistic.

Certification Schemes

Suitable schemes may be accepted by Building Control Bodies as evidence of compliance.

Residential Sprinklers

The use of sprinkler systems in accordance with BS 9251:2005 is recognised. Note that the Govt still needs convincing regarding the effectiveness of such systems but recognise they are a satisfactory compensatory measure.

Alternative Approaches

HTM 05 “Firecode” should be used for the design of residential care premises.

BB100 should be used for the design of schools. (This document has not been published yet)

B1

Fire Alarms in Flats

The guidance on smoke alarms in flats has been amended such that alarms should be installed in accordance with BS 5839- 6:2004. Simple guidance has been retained, in the form of a commentary on this standard, so that most users of the Approved Document will not necessarily need to obtain a copy of the standard. All smoke alarms should have a standby power supply.

Fire Alarms

The guidance for buildings other than dwellings has been updated to take account of the 2002 edition of BS 5839-1:2002.

Means of escape - Flats

Self closing devices are only required to flat entrance doors and doors enclosing common staircases. (Refer Appendix B paragraph 2.)

Locks and child resistant safety stays may be provided on escape windows. (Refer paragraph 2.9 Note 2.)

New guidance has been provided on the provision of inner rooms (Refer paragraph 2.5) and galleries (Refer paragraph 2.8 and Diagram 1.)

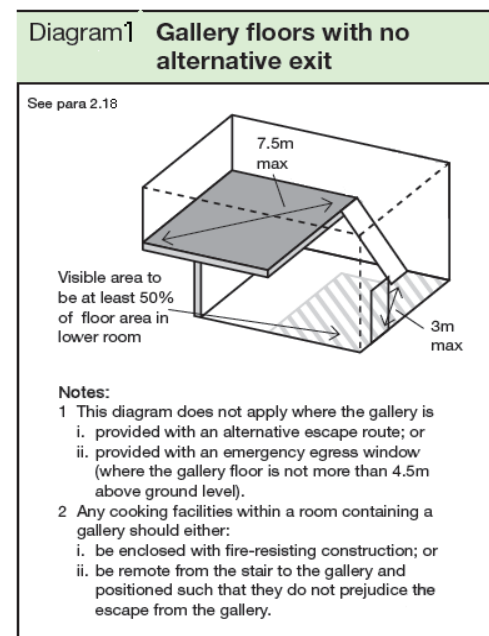

Additional options of providing sprinkler protection and/or a protected stairway instead of alternative escape routes has been included for flats with more than one storey. (Refer paragraph 2.16.)

Guidance on the use of air circulation systems in flats with protected entrance halls or stairways is given. (Refer paragraph 2.18.)

The provisions for smoke control in the common areas of flats have been changed, recognising the greater use of mechanical ventilation. (Refer paragraph 2.26 & 2.27.)

The trend for Live/Work units has now been included in the document and guidance provided (Refer paragraph 2.52.)

Means of escape - Other Buildings

Guidance on means of escape in buildings with open special planning has been included. (Refer paragraph 3.12 and Diagram 14.)

Diagram 14 Open connections

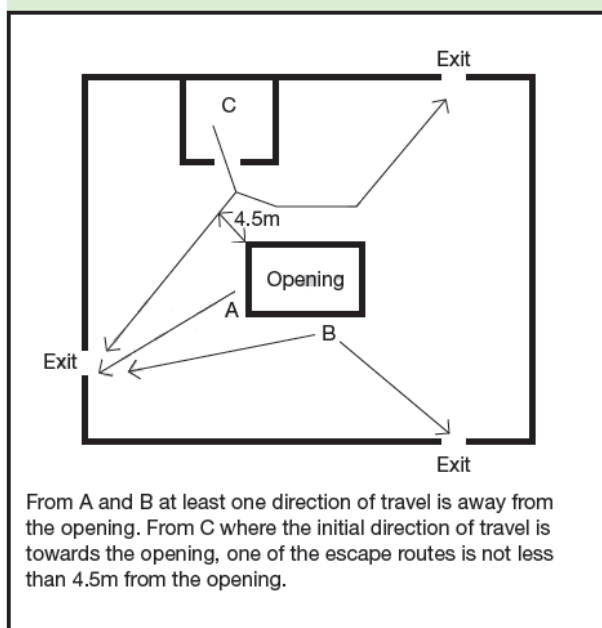

A method has been provided for calculating acceptable final exit widths for merging escape routes at ground floor level. (Refer paragraph 3.23.)

Guidance on the provision of cavity barriers associated with subdivided corridors has been moved to Section 3 and clarified. (Refer paragraph 3.26 and Diagram 16.)

Diagram 16 Subdivision of corridors

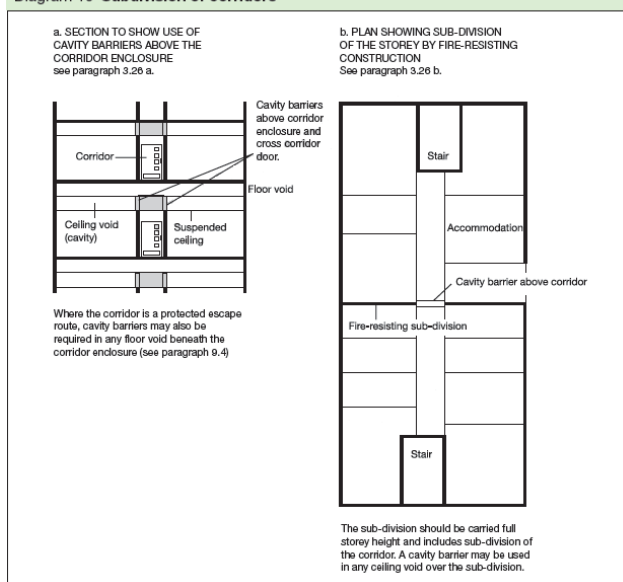

Guidance applicable to small premises, previously in BS 5588-11:1997, has been incorporated into the document. (Refer paragraph 3.32-3.37, 4.6 & 4.33.)

New guidance on the design of residential care homes has been given including the use of sprinklers and/or free swing door closing devices. Greater flexibility is also given where sprinkler systems are provided. Consideration also to be given to management capabilities and dependency of occupants. (Refer paragraph 3.8-3.52 and Diagram 19.)

Diagram 19 Progressive horizontal evacuation in care homes

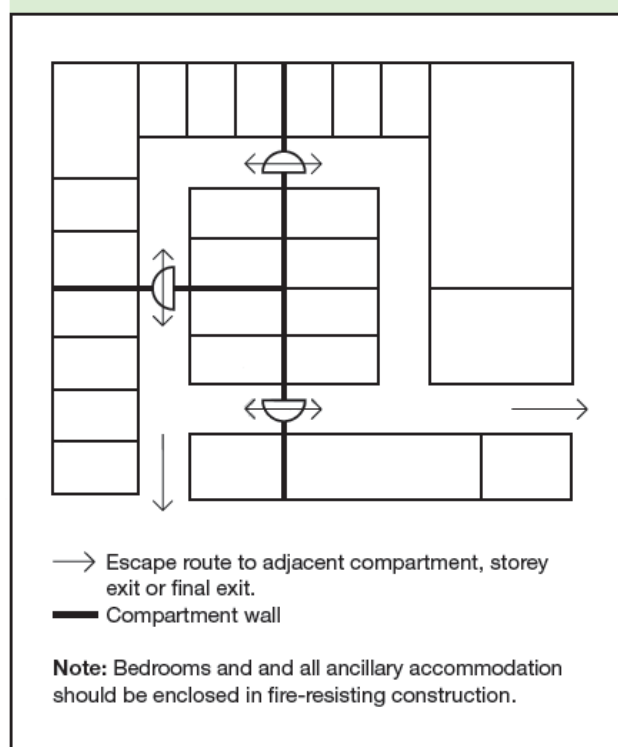

Guidance on means of escape for disabled people has been incorporated in the general guidance. The requirements should also be used with a realistic approach to the management of an incident. (Refer paragraph 4.7-4.14.)

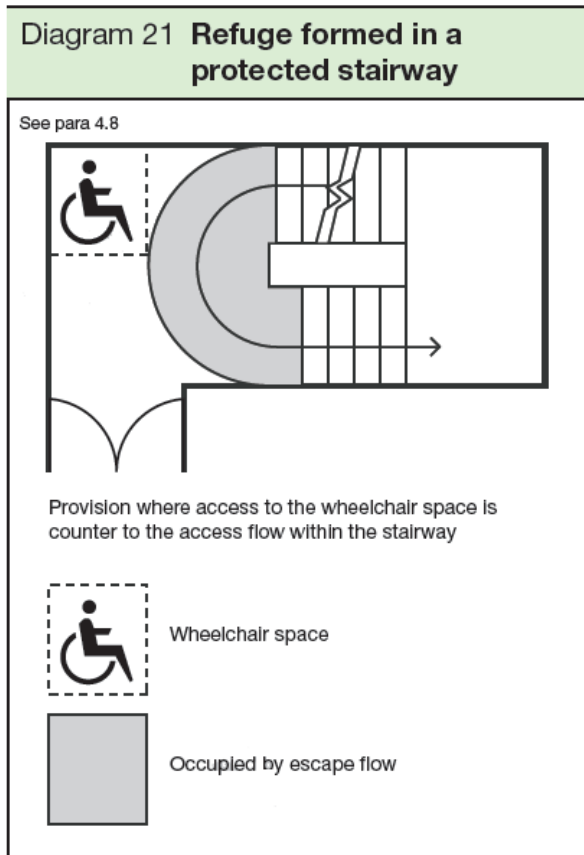

Following '9/11' research into evacuation of tall buildings has been amended. In tall buildings with phased evacuation, consideration needs to be given to the interaction of firefighters with people attempting to evacuate the building. (Refer paragraph 4.26-4.30.)

General guidance has been amended in relation to power circuits (refer paragraph 5.38) and requirements from the British Standard have been incorporated into the document for emergency lighting. (Refer paragraph 5.36)

More detailed guidance has been provided on the protection of ventilation systems. (Refer paragraph 5.46-5.53)

B2

Equivalent Euro Classes for wall and ceiling linings have been introduced. (Refer paragraph 6.1.)

B3

Compartment Walls

The predicted deflection of a floor, in the event of a fire, should be accommodated into the design of compartment walls. (Refer paragraph 8.27.)

Sprinkler protection in flats

Sprinkler systems should be provided in blocks of flats exceeding 30m in height. (Refer paragraph 8.14.)

Warehouses

As a result of the creation of 'super storage' warehouses becoming larger, a maximum compartment size has been introduced for unsprinklered single storey warehouse buildings. (Refer to Table 12)

Concealed Spaces (cavities)

This section has been completely restructured. Table 13 (AD B 2000) has now been incorporated into the text to reduce confusion. A new diagram indicating provisions for cavity barriers has been provided. See Diagram 33.

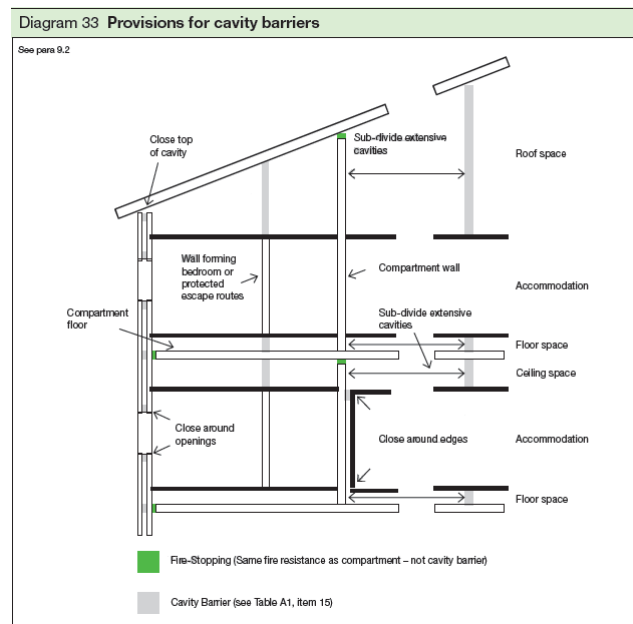

Openings

Window and door frames should only be regarded as cavity barriers if they are constructed of steel or timber of an appropriate thickness. (Refer paragraph 9.13.)

Under Floor Voids

Extensive cavities in floor voids should be subdivided with cavity barriers. (Refer paragraph 9.11.)

Fire dampers

Guidance on the specification and installation of fire dampers has been provided. (Refer paragraph 10.9-10.14.)

Car Parks

Non combustible materials should be used in the construction of a car park for it to be regarded as 'open sided' for the purposes of establishing the necessary period of fire resistance. Other car parks should achieve the standard period of fire resistance. (Refer paragraph 11.2-11.6.)

B4

Notional Boundaries

Space separation should be considered where more than one building is on the same site but operated by different 'organisations'. (Refer paragraph 13.6.)

Roof Coverings

The guidance on roof coverings incorporates the new European system of classification set out in BS EN 13501-5:2005. (Refer paragraph 14.5.)

B5

Private Hydrants

A building with a compartment of 280m² or more, constructed more than 100m from a highway, should be provided with suitable fire hydrants. (Refer paragraph 15.7-15.8.)

Vehicle Access

There should be access for a pump appliance to within 45m of **all** points within a dwelling or a suitable fire main should be provided. (Refer paragraph 16.3.)

Firefighting Shafts

Assembly buildings with a floor area exceeding 900m², where the floor height is more than 7.5m above fire and rescue service vehicle access level, should be provided with firefighting shafts

which need not include firefighting lifts. (Refer paragraph 17.3.)

Diagram 52 Components of a firefighting shaft

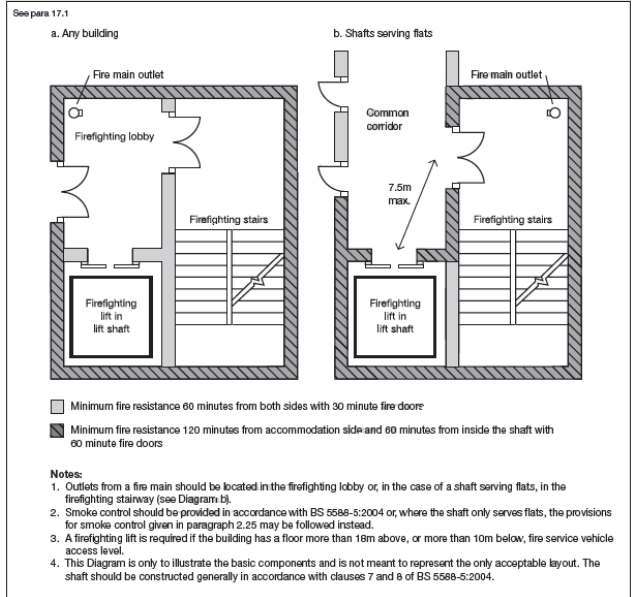

Hose distances

In unsprinklered buildings every part of storeys over 18m in height should be within 45m of a fire main outlet. (Refer paragraph 17.10.)

Appendix B

Self-Closing Devices

Fire doors within flats need not be provided with self-closing devices.

Appendix C

Occupant capacity

The floor space factors table has been updated and moved to this Appendix. (Refer to Table C1)

Door widths

The method of measurement for door widths has been changed to align with Approved Document M. (See Diagram C1.)

Smoke ventilators

Guidance is given on the measurement of the free area for smoke ventilators. (See Diagram C7.)

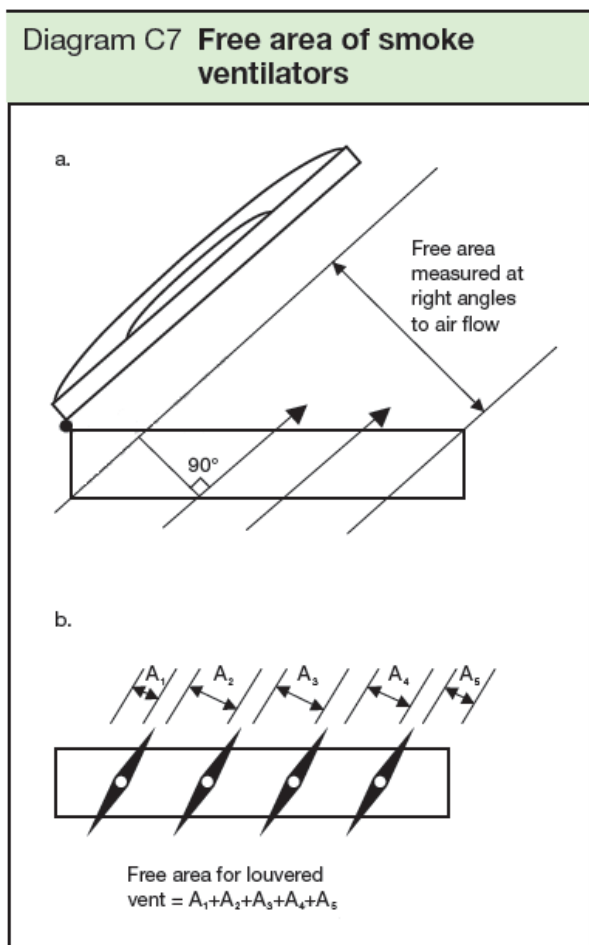

Appendix F

The behaviour of core insulated materials in a fire situation has been introduced following several fires where these materials contributed to the size of the fire. (ie polystyrene, polyisocyanurate, composite polymers)

Appendix G

Fire Safety Information

This new Appendix provides guidance on the new requirement for fire safety information to be recorded and passed on to the 'responsible' person.

Useful links:

<http://www.communities.gov.uk>
<http://www.planningportal.gov.uk>
<http://www.regulatoryreformorder.org.uk>

Disclaimer

This guidance note sets out to highlight the main changes to Approved Document B – Volume 1 – Dwellinghouses. Harrow Council cannot be held responsible for any errors made in producing this document. Reference should be made to the Approved Document.



Certificate No. FS 35182

Produced by **Harrow Building Control**
Harrow Council, PO Box 37, Civic 1
Station Road, Harrow HA1 2UY

email bcontrol@harrow.gov.uk web www.harrow.gov.uk